*DESIGN AND CONSTRUCTION OF CONTACTLESS ANTI-
COVID19 MACHINE*

Otuu Obinna Ogbonnia

*Department of Computer Science, Federal Polytechnic Oko Anambra State.
obynoses@federalpolyoko.edu.ng*

AND

Edim Bassey Edim.

*Department of Computer Science, University of Calabar.
Edime@unical.edu.ng*

ABSTRACT

Covid-19 has introduced us to new normal of social distancing, covering our noses with face masks, and washing of our hands regularly. The disease is communicable to the extent that there is danger when one touches a surface used by a carrier. This poses a challenge as nobody knows when the next person has gotten the disease, and as such, even washing of hands with tactile interface becomes a problem. This is why the researchers constructed a contactless machine which dispenses liquid soap, water and sanitizer when the hand goes close to any of the three outlets. This device was powered by a 9v battery in a way that it does not need to be triggered manually but to just place the hand near the bottle to automatically turn ON the circuit to dispense the sanitizer. This was workable when tested and had a dispensing time of one seconds (1s). The device was found to be suitable for homes, schools, churches, hospitals and various workplaces.

KEYWORDS: Automatic, Alcohol-based, dispenser, sensor-activated, passive-infrared sensor.

INTRODUCTION

Coronavirus disease (COVID-19) is an infectious disease caused by a newly discovered coronavirus. The virus that causes COVID-19 is mainly transmitted through droplets generated when an infected person coughs, sneezes, or exhales. These droplets are too heavy to hang in the air, and quickly fall on floors or surfaces (Lotfinejad *et al.*, 2020). The virus spreads

by breathing in the virus when in close proximity with someone who has COVID-19, or by touching a contaminated surface and then the eyes, nose or mouth. The novel coronavirus (SARS-CoV-2) responsible for the current pandemic of coronavirus disease (COVID-19) that originated in Wuhan, China, in December 2019, has now spread to 113 countries and territories outside of China (Hung *et al.*, 2020). SARS-CoV-2 is a betacoronavirus that infects humans and

the disease presents mostly with fever, cough and dyspnea (Sun *et al.*, 2020).

There is currently no vaccine to prevent coronavirus disease 2019 (COVID-19). The best way to prevent illness is to avoid being exposed to this virus. To prevent the spread of the virus, it is advisable to clean the hands frequently and thoroughly using an alcohol-based hand sanitizer or wash the hands with soap and water (Doronina *et al.*, 2019).

The hands are a critical vector for transmitting microorganisms (Edmonds, 2015). The cross-transmission of these organisms to others occurs when we fail to wash hands effectively. Within healthcare systems and services, there have been almost continual awareness campaigns in place to encourage hand washing among health service personnel, patients and visitors.

Throughout any given workday, employees use their hands to write up a report, shake hands with a new client, open doors and much more. All of these activities expose hands to harmful germs and bacteria. Considering that 80 percent of all infections are transmitted by hands, it's crucial to implement an effective hand hygiene program at work (Pittet, 2011).

Hand hygiene with alcohol-based hand rub (ABHR) is widely used around the world as

one of the most effective, simple and low-cost procedures against COVID-19 cross-transmission (WHO, 2020). By denaturing proteins, alcohol inactivates enveloped viruses, including coronaviruses, and thus ABHR (Alcohol-based hand rubs) formulations with at least 60% ethanol have been proven effective for hand hygiene (Kamming *et al.*, 2020).

Nigerians spend more time Monday through Friday at the workplace than anywhere else, including their home. Additionally, 90 percent of office workers will go to work even when they are sick, in part due to an ever-growing workload. This makes the workplace a hotbed for germs and bacteria. And this year's flu season could be worse than normal as experts are warning that this year's flu vaccine may only be 10 percent effective.

The good news is that proper hand hygiene compliance can reduce absenteeism and associated costs by 40 percent. While washing hands with soap and water is the best way to ensure hands are properly washed and rid of germs, it isn't always a viable option. However, there is a simple solution: hand sanitizer. According to the World Health Organization (WHO) and the NCDC, hand sanitizer is one of the best tools available to avoid getting sick and spreading germs. By placing hand sanitizer

in strategic locations throughout the office, and other high traffic areas, the employees can be encouraged to improve their hand hygiene and make the office a healthier working environment (Sax *et al.*, 2009).

Organizations that encourage regular use of hand sanitizer tend to have healthier workers. A study featured in BMC Infectious Diseases found that office workers who were encouraged to use an alcohol-based hand sanitizer at least five times each workday were about two-thirds less likely to get sick than those who continue to just wash their hands. In this corona period hand sanitizer is an essential thing because it can decrease the chances of contacting Covid -19 virus.

When an infected person presses the bottle trigger, the virus may spread from the hand sanitizer bottle. This can be solved by using automatic hand sanitizer bottle. Automatic means, no need to trigger with the hand. Just place the hand near the bottle. The bottle will automatically trigger. This contactless hand sanitizer circuit facilitates the user to access the sanitizing liquid on hands automatically without the need of operating or touching the sanitizer bottle pump manually. This feature ensures that viruses have no chance of spreading through physical touching of the sanitizer bottle and its operating parts.

At the successful completion of this study, the entire public will benefit from its results. They will benefit from this study because hand washing is one of the best ways to protect people and family from getting sick.

In the educational setting, it's a reality that the classrooms are always crowded with students shaking hands, exchanging pleasantries and exchanging writing and studying materials. Workers in offices are not left out; workers are seen exchanging writing materials and pleasantries. Money they say is a legal tender, the entire public exchanges currencies because it is generally acceptable. All these are done with the hands which might have picked germs in the toilet, bathrooms or other places. These germs can be transferred from one person to another through exchange of pleasantries and money, thus, the need for an automatic hand sanitizer dispenser. This study is carried out in a quest to reduce the spread of germs from one person to another. Therefore, the benefits and significance of this study cannot be overemphasized.

In order to actualize the objective of this study, diodes, Vero boards, rectifiers, 9V battery and other components connected together were used so as to construct an automatic hand sanitizing dispenser that is workable and durable. These connections were made with the help of discrete units

such as the power unit (made of 9V DC battery), timing unit (which has the IC 555 in its monostable state) and the sensing unit which has the PIR (passive Infrared) as its chief component.

MATERIALS AND METHODS

The components that were used for the construction are 9V battery, Light Emitting diodes (LEDs), Transistors, 555 timer, resistors, solenoid, and passive infrared (PIR) sensor. The above components were bought from 41 Iweaka Road at PATECH electronic store. The components were connected as in the circuits diagram.



Fig 1.0 Block diagram of automatic hand sanitizer dispenser (Swagatam, 2020)

POWER SUPPLY UNIT

The power supply unit supplies electrical power to the other units of the circuit. At power ON situation the circuit triggered to dispense alcohol based sanitizer. The power supply unit consist of a 9V DC battery.

SENSING UNIT

The sensing unit is made up of a PIR (Passive Infrared) sensor which converts electromagnetic signals to electrical signals. The term passive indicates that the sensor does not actively take part in the process, meaning it does not itself emit the referred infrared red signals, rather passively detects infrared radiation

BLOCK DIAGRAM OF AN AUTOMATIC HAND SANITIZER DISPENSER

emanating from warm blooded animal in the vicinity (Swagatam, 2020).

TIMING UNIT

The timing unit was implemented using a 555 timer in its monostable mode. A monostable multivibrator, is a sequential logic circuit that generates an output pulse. When triggered by the PIR, a pulse of pre-defined duration was produced. The circuit then returned to its stable state and produces no more output until triggered again.

To calculate the delay, the monostable multivibrator was used as a timer:

$$T = 1.1R_1 \times C_1$$

Where, $R_1 = 470k$

$$C_1 = 2.2\mu F$$

$$\text{Therefore, } T = 1.1 (470 \times 2.2)$$

$$= 1,137.4mS$$

$$= 1.1s$$

OUTPUT UNIT

The output unit consist of a solenoid which gets activated by the monostable multivibrator for some moment of time as

determined by its RC timing components. The activation of the solenoid causes its central spindle to quickly push and pull in the vertical direction, pressing the pump handle of the sanitizer bottle once.

This eventually causes the bottle to dispense the sanitizing liquid into the hand of the user.

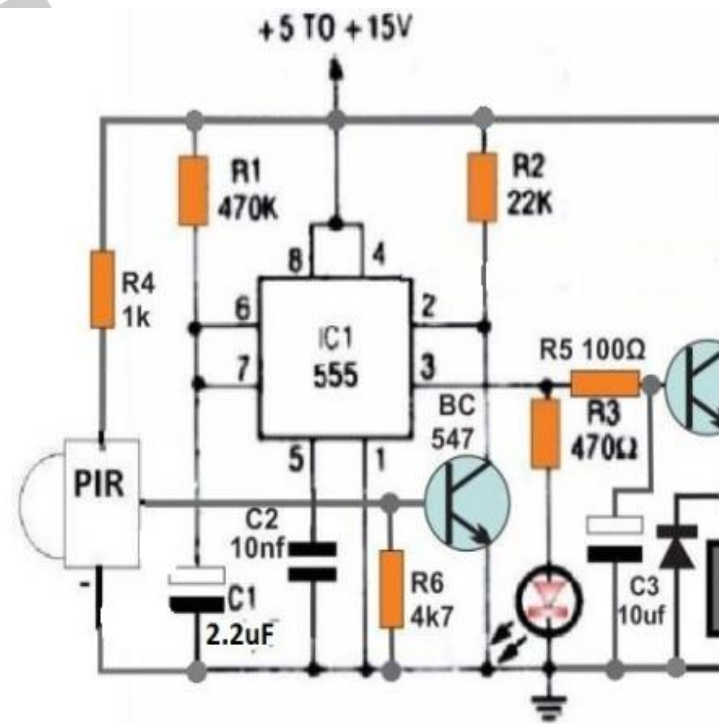

Fig 2.0: Circuit diagram of automatic hand sanitizer dispenser (Swagatam, 2020)

RESULTS

Fig2.0 shows a standard IC 555 monostable circuit. When pin2 was grounded, it caused the output pin3 to go high for a period decided by the R1, C1 values.

In this automatic sanitizer dispenser design, the R1, C1 were calculated to produce an approximately 1 second output high, in response to a low signal at pin2. When the PIR detected a human hand, it conducted and switch ON the BC547 transistor which in turn triggered the pin2 of the IC. This instantly caused the pin3 to go high and the TIP142 transistor was activated and the connected solenoid, generated a 1 second long push and then a shutdown pull-up on the solenoid shaft. The pull was generated by the attached spring tension on the solenoid shaft. Again, in this version also the solenoid was seen connected at the emitter side of the transistor in order to enable a soft thrust on the solenoid shaft depending on the charging response of C3.

Therefore, an automatic hand sanitizer that dispenses alcohol-based sanitizer in 1s with sensitivity range of 2meters (adjustable) was constructed and was confirmed working when subjected to test.

CONCLUSION AND RECOMMENDATION

Automatic hand dispensers are not just modern and fancy-looking but also very convenient. The most significant and most

crucial advantage of an automated hand sanitizer compared to a regular one is the fact that it can be used without actually touching. That eliminates a contact point and means fewer micro-organisms and a cleaner surface for a longer time. They also deliver a standardized dose of sanitizer every time, which is pretty cool and convenient.

The overall design of this dispenser is modern and straightforward, it can be kept on the countertop or wall-mounted. And also it comprises of a sensor which detects the hands from as far as 2 meters.

Hence, the hand sanitizer dispenser is contactless, sensor-activated and suitable for homes, schools, churches, health care sector and workplace, e.t.c.

One problem with this circuit is that the PIR sensor can be activated by any warm blooded animal or even a warm wind thereby giving a false trigger, therefore, it is recommended that more sophisticated sensors should be incorporated to the circuit to avoid false triggering.

REFERENCES

- [1] Alzywood, M., Jackson, D., Brooke, J., and Aveyard, H. (2018). An integrative review exploring the perceptions of patient involvement in promoting hand hygiene compliance in the hospital setting. *Journal of chemical Nursing*, 7(27), pp. 1329-1345
- [2] Doronina, O., Jones, D., Martello, M., Biron, A., and Lovoie, T.M. (2017). A systematic review on the effectiveness of interventions to improve hand hygiene compliance Nurses in the hospital setting. *Journal of Nursing scholarship*. 49, pp. 143-145
- [3] Edmonds, W.S., Nurinova, N.I., Zakpa, C.A., Fierer, N., Wilson, M. (2015). Review of human hand microbiome research. *Journal of Dermatological science*, 9(80), pp. 3- 12
- [4] Huang, C., Wang, Y.,u, Lix, H., Ren, L., Zhao, J., Hu, Y. (2020). Clinical features of patients infected with 2019 novel coronavirus in Wuhan. *Clinical Lancet*. 2020; 395, pp. 497-506
- [5] Kamming, D., Gardon, M., and Chury, F. (2003). Anaesthesia and SARS. *Br J. Anaesth*. 10(90), pp. 715-718
- [6] Lotfinejad, N., Peter, A., and Pittet, D. (2020). Hand hygiene and the novel coronavirus pandemic: the role of healthcare workers. *Emerging Infectious Diseases*. 105(4), pp. 776-777
- [7] Pittet, S.D. (2011). Improving adherence to hand hygiene practice: A multidisciplinary approach. *Emerging infectious Diseases*, 7: 234-238
- [8] Sax, M., Allegranzi, B., Characti, M.N., Boyce, J., Larson, E., and Pittet, S.D., (2009). The World Health Organisation hand hygiene observation method. *American Journal of Infection Control*. 37: 827-834
- [9] Sun, P., Lu, X., Xu, C., Sun, W., and Pan, B., (2020). Understanding of covid-19 based on current evidence. *J. med. Virol*, 20(5), pp. 240-247
- [10] Swagatam, D., G. (2020). Automatic hand sanitizer circuit – Fully contactless. <http://homemadecircuits.com>